

[54] TOY VEHICLE

[75] Inventors: George W. Lucas, Jr., San Anselmo; Joseph E. Johnston, Fairfax, both of Calif.

[73] Assignee: Lucasfilm, Ltd., San Rafael, Calif.

[**] Term: 14 Years

[21] Appl. No.: 231,674

[22] Filed: Feb. 5, 1981

[51] Int. Cl. D21-01

[52] U.S. Cl. D21/134; D21/59; D21/87; D21/148

[58] Field of Search D21/124, 128, 132, 134, D21/135-137, 140, 148, 76, 78, 74, 59, 87; 46/1 R, 1 B, 115, 118

[56] References Cited

U.S. PATENT DOCUMENTS

2,482,334 9/1949 Fernald D21/74

OTHER PUBLICATIONS

Daiya Catalogue '80, p. 5, #730, B/O Gantry Crane. Wards Xmas Catalog, 1978, p. 361, Item "P" Acroyear.

Primary Examiner—Charles A. Rademaker
Attorney, Agent, or Firm—Townsend and Townsend

[57] CLAIM

The ornamental design for a toy vehicle, substantially as shown and described.

DESCRIPTION

FIG. 1 is a front perspective view of a toy vehicle showing my new design; FIG. 2 is a right side perspective view thereof; FIG. 3 is a left side perspective view thereof; FIG. 4 is a rear perspective view thereof; FIG. 5 is a right side perspective view of a modified form of the design shown in FIGS. 1 through 4; FIG. 6 is a top plan view thereof; FIG. 7 is a rear elevational view thereof; FIG. 8 is a front elevational view thereof; and, FIG. 9 is a bottom plan view thereof.

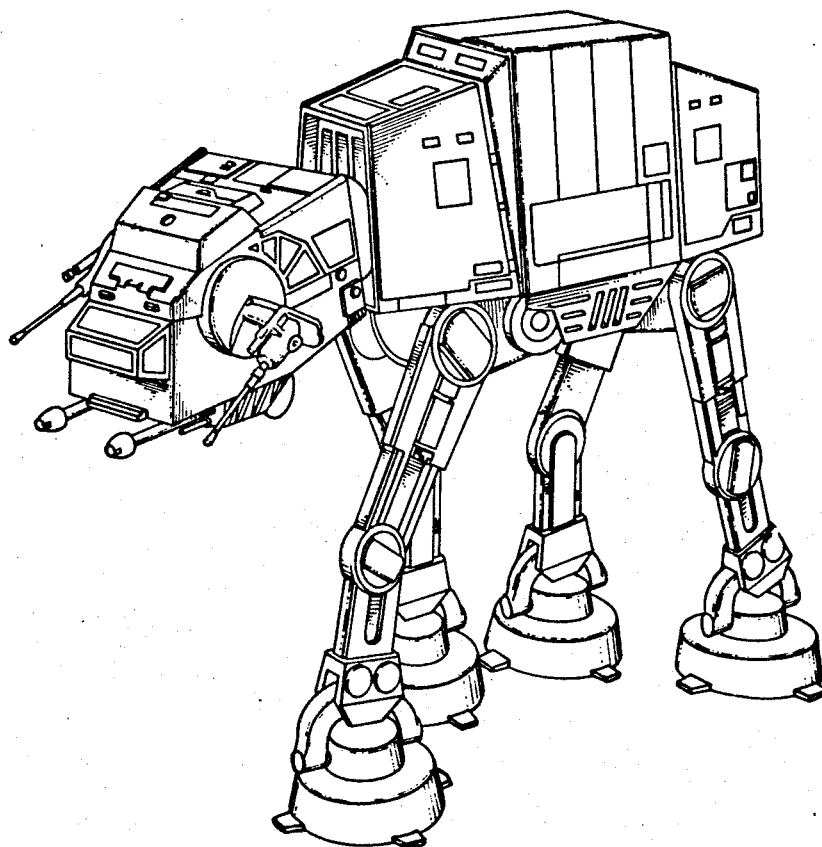

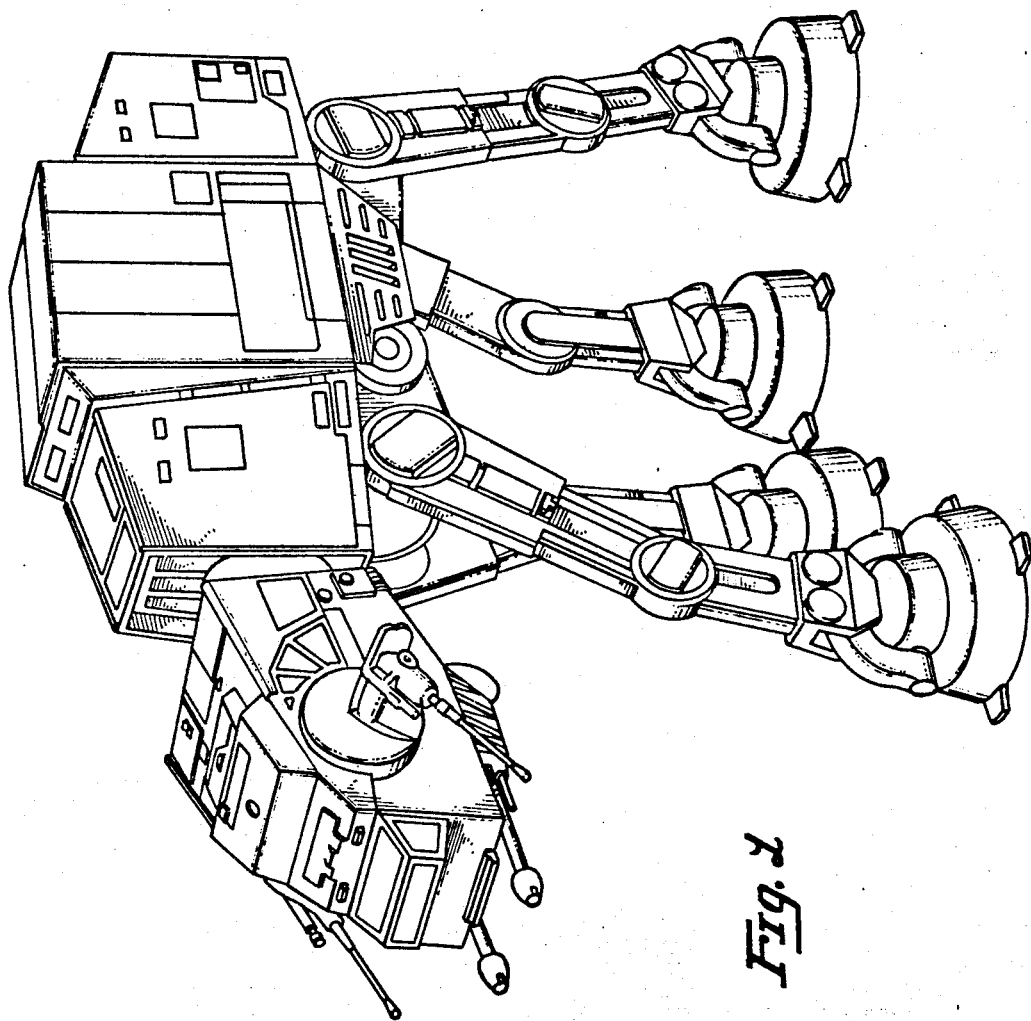

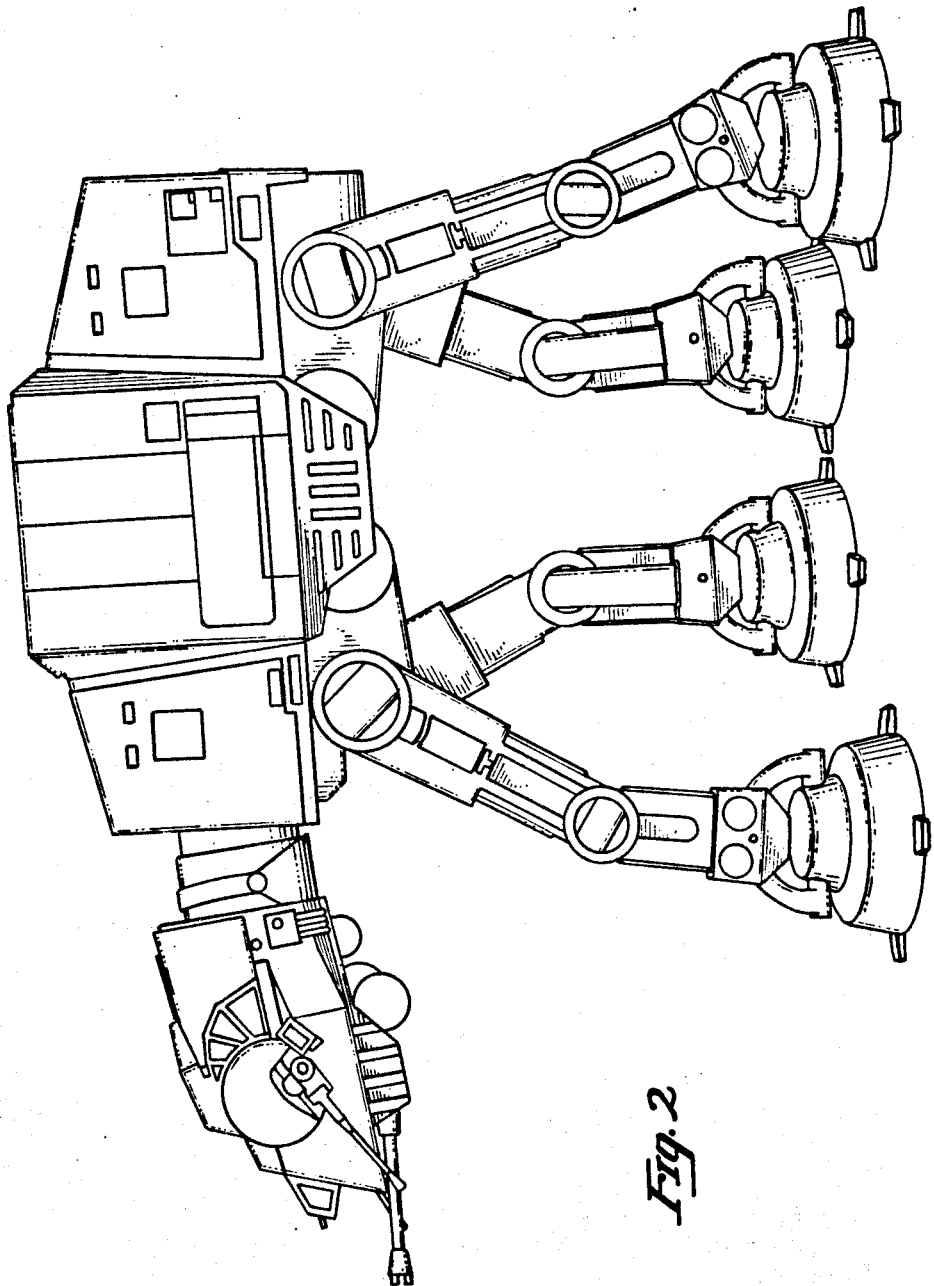

Fig. 2

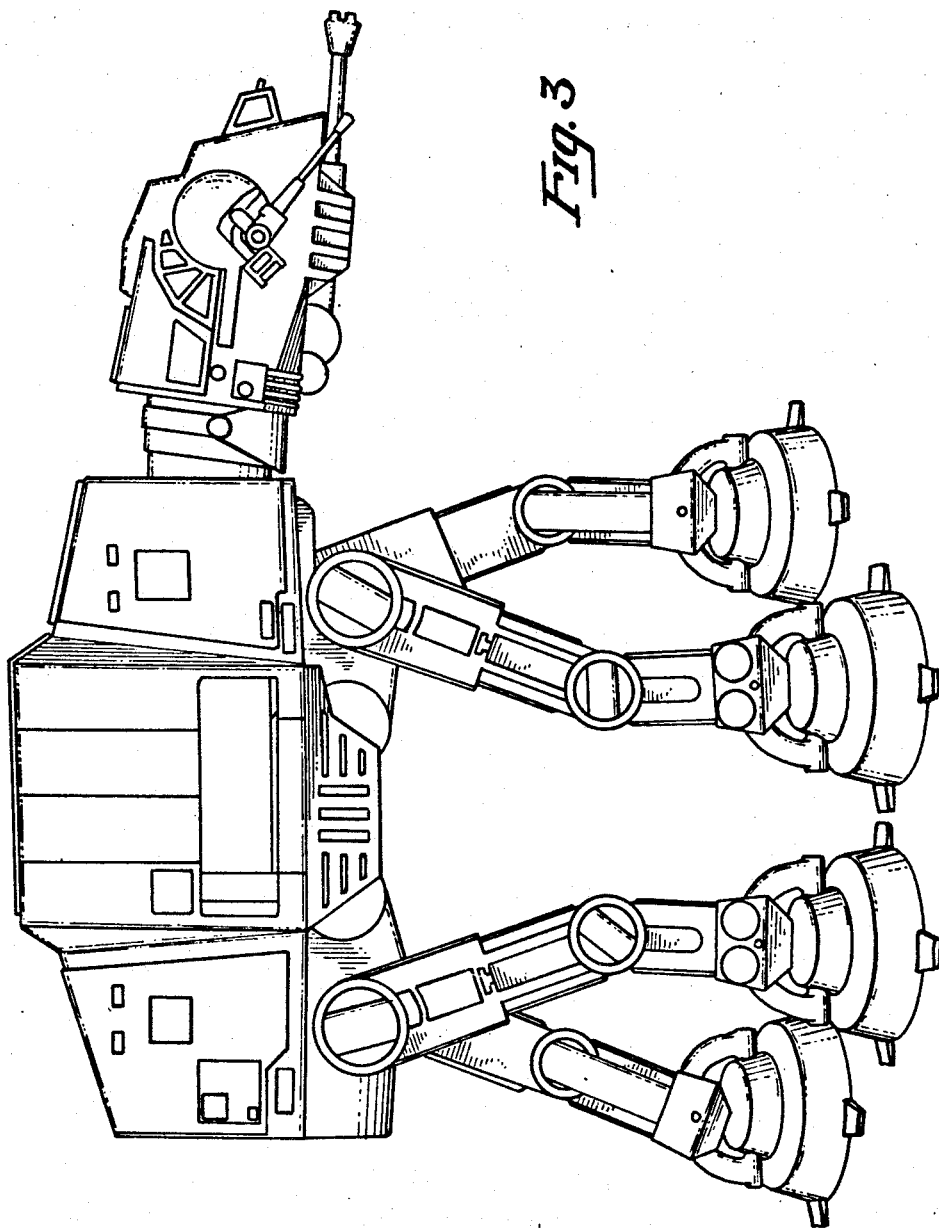

Fig. 3

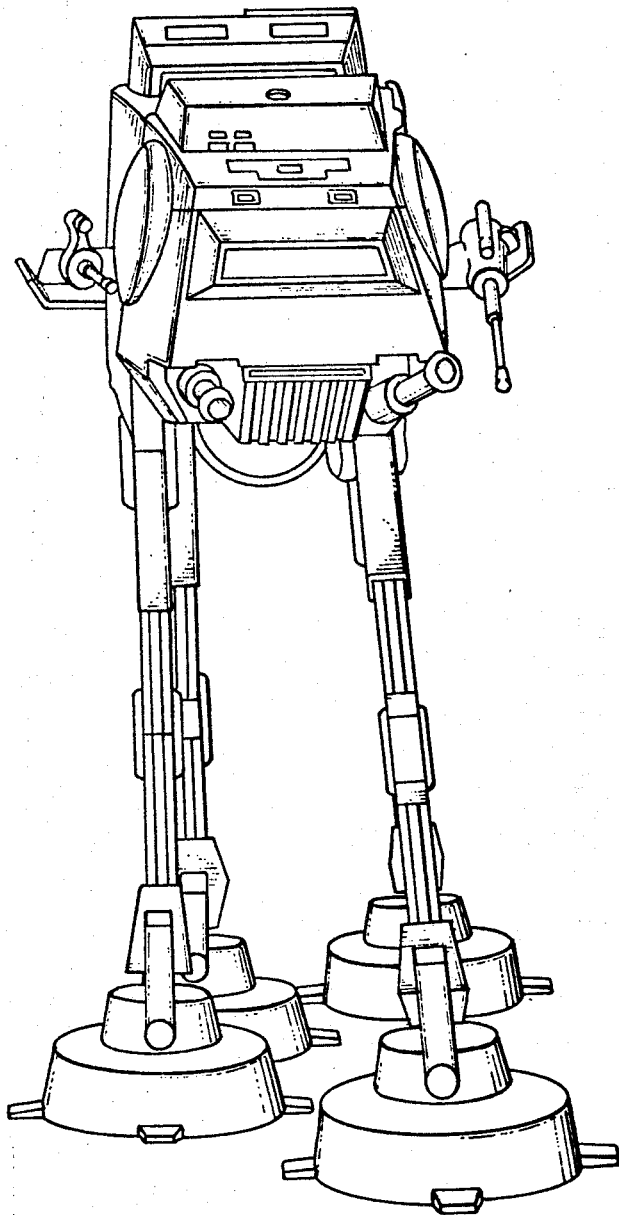

Fig. 4

FIG. 5

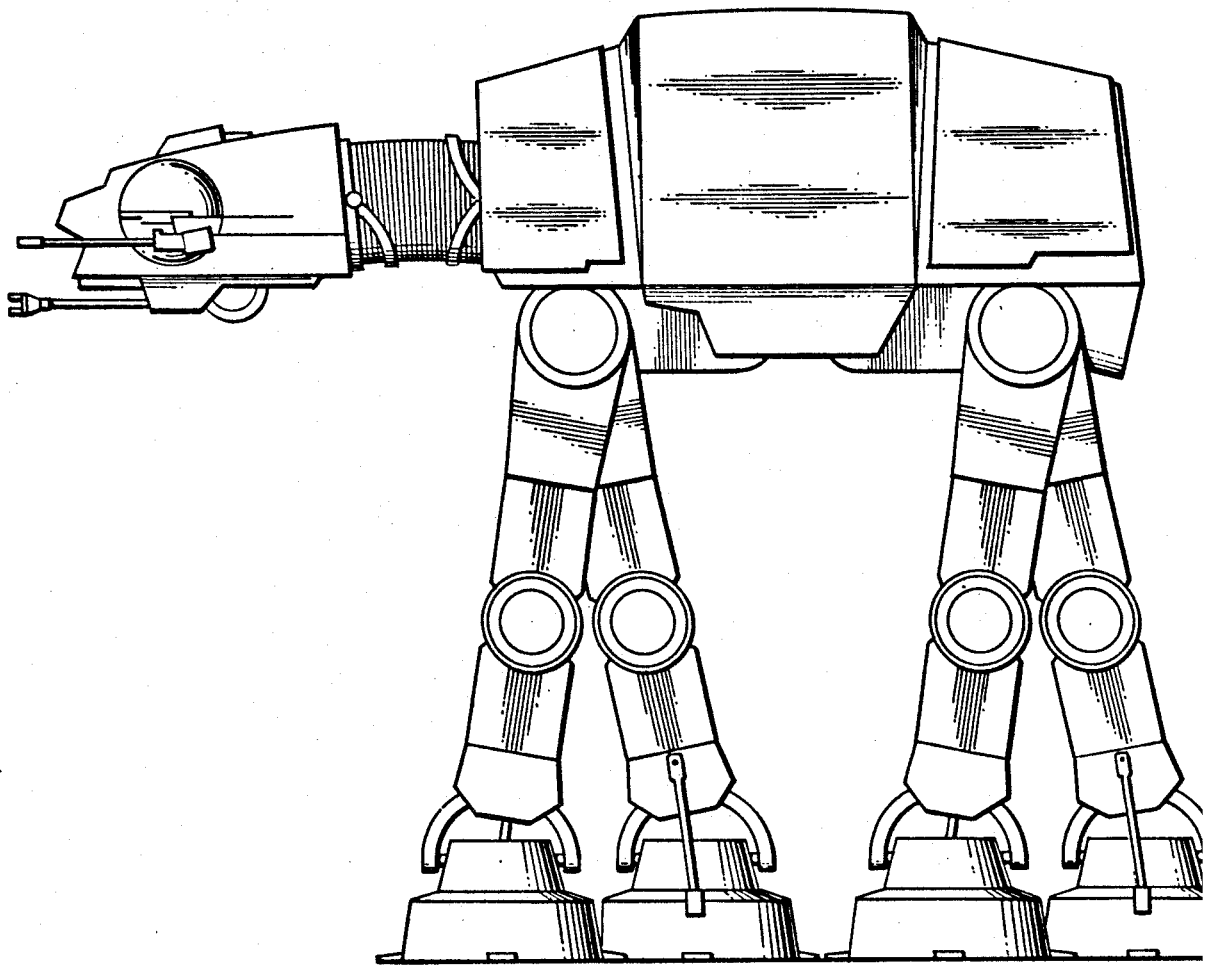
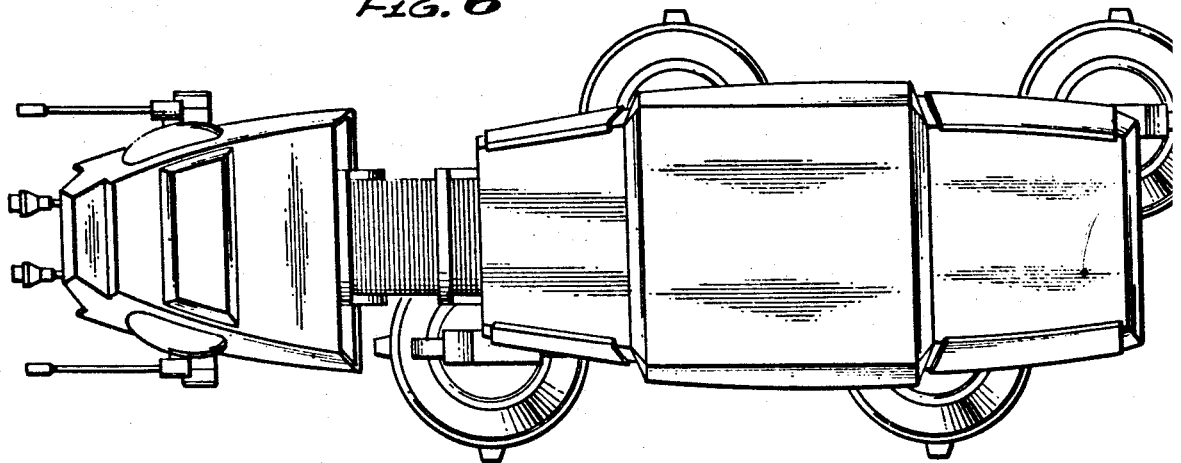

FIG. 6



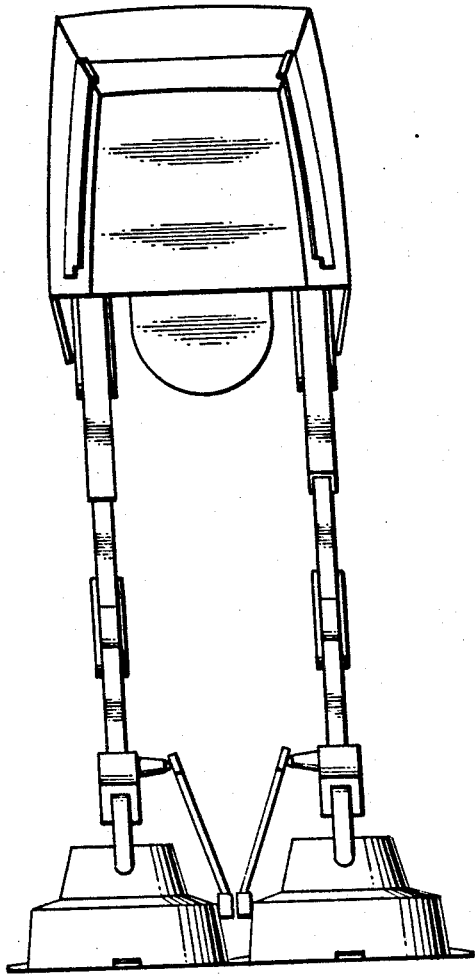

FIG. 7

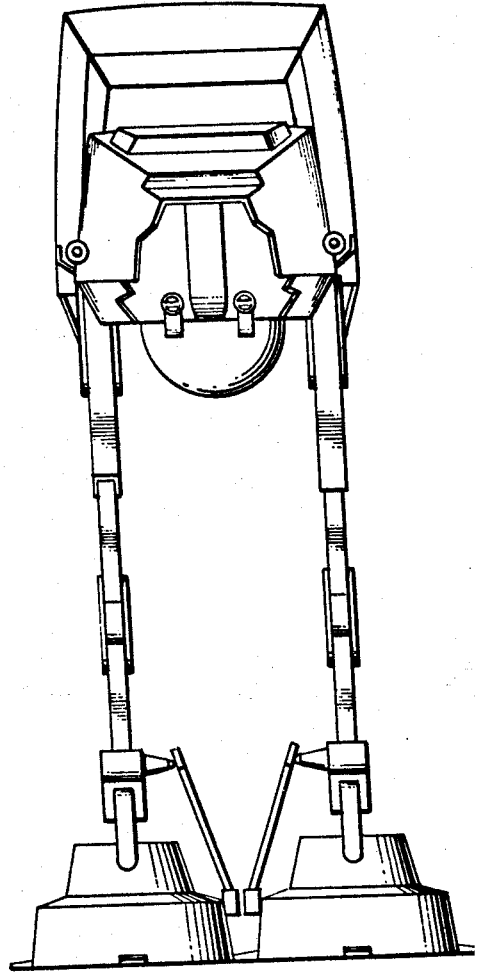

FIG. 8

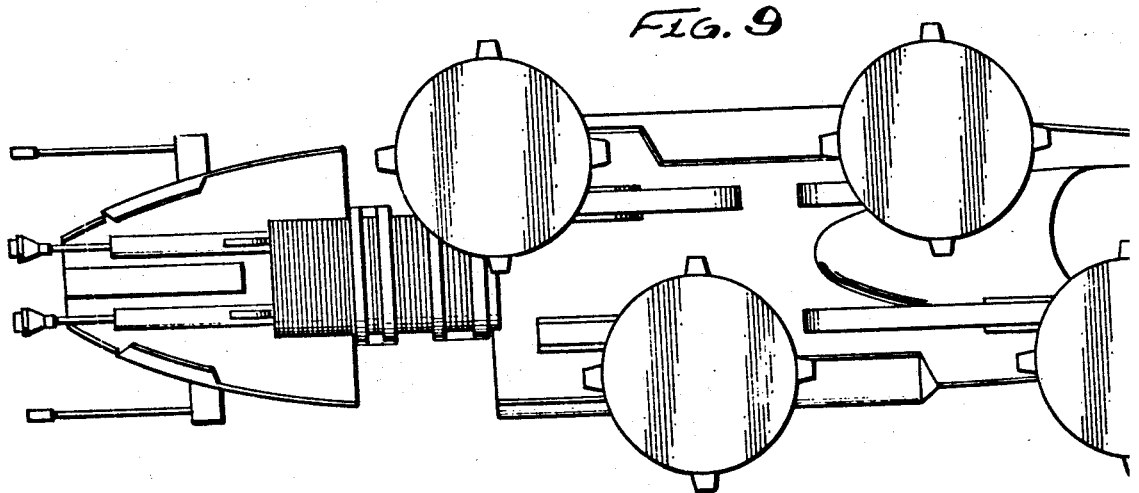

FIG. 9